

***YOUR TRUSTED PARTNER
ON THE SEAS***

PRODUCT RANGE



ALAMARIN-JET

CONTENT

ABOUT US 4

WATERJETS - Omega Series

Omega Series is specifically designed to meet the diverse needs of various vessel categories. It is an ideal choice for Commercial Crafts, offering reliability and performance for heavy-duty operations. In Governmental Applications, it ensures precision, durability, and efficiency under demanding conditions. For Passenger Ferries, it provides smooth and safe transportation with exceptional maneuverability. Additionally, its premium features and advanced engineering make it a perfect fit for luxurious Yachts, delivering unmatched performance and comfort.



Omega 42 - 1500 kW (2040 MHP) 6

Omega 37 - 1000 kW (1360 MHP) 8

WATERJETS - AJ Series

AJ 340 - 550 kW (750 MHP) 10

AJ 340 is a lightweight, compact, and highly efficient commercial waterjet. Cavitation limits are the highest in its class thanks to Alamarin-Jets leading hydrodynamic design, without reducing top speed capabilities. AJ 340 is suitable for large military and commercial fast craft, as well as pleasure craft applications.

AJ 285 - 368 kW (500 MHP) 12

AJ 285 is the newest waterjet in the COMBI-FRAME series. By choosing between two different hull installation inserts allows the waterjet to be installed either in a LONG TAIL or SHORT TAIL configuration. Following the success of AJ 245 many customers requested the combi-frame installation method for larger, more powerful vessels.

AJ 245 - 235 kW (320 MHP) 14

AJ 245 is the first waterjet in the COMBI-FRAME series. The patented Combi-Frame technology allows designers, builders, and owners maximum flexibility in positioning the propulsion system within the vessel.

AJ 230 - 190 kW (260 MHP) 16

AJ 230 is the best-selling Alamarin-Jet product of all time and is now the industry standard for SOLAS Fast Rescue Craft. It is renowned worldwide for its extremely robust and simple design, while maintaining high cavitation limits and exceptional high-speed performance.

AJ 180/185 - 120 kW (163 MHP) 18

AJ 180 and AJ 185 are frequently used in leisure, commercial, and hybrid/electric applications, with the majority of installations found in luxury pleasure tenders and small commercial vessels, often requiring SOLAS certification. As with all Alamarin-Jet products, there are no limitations on operational profiles.

AJ 160 - 100 kW (136 MHP) 20

AJ 160 is the smallest waterjet in the Alamarin-Jet range, primarily used in luxury pleasure tenders and small commercial vessels. It is the only commercially rated waterjet of its size available, and as with all Alamarin-Jet products, there are no limitations on operational profiles.



CONTROL SYSTEMS

SIGMA CONTROL SYSTEM 22

Sigma Control System is an electro-hydraulic, integrated drive-by-wire control system. It supports installations ranging from single to quadruple waterjets.

ACTUATOR CONTROL UNIT - ACU 24

Actuator Control Unit (ACU) system is a modular propulsion control solution designed for adaptability across multiple configurations through the simple selection of modular components.

DELTA DP CONTROL SYSTEM 26

Delta DP is a modular, high-level propulsion control system that integrates the vessel's propulsion, steering, and navigation systems. It offers three main control modes: Manual Control, Dynamic Positioning Mode, and Autopilot Mode.



ABOUT US

At **Alamarin-Jet Oy** we specialize in providing **waterjet propulsion units and control systems** designed to excel in a variety of marine applications. Whether you're powering a leisure yacht, a commercial vessel, or a high-performance craft, our products are engineered to deliver optimal performance and efficiency.

Our range of waterjet propulsion units and control systems accommodates input power of **up to 1500 kW / 2040 HP**, ensuring that even the most demanding marine environments are met with power and precision. Backed by cutting-edge technology and years of expertise, our solutions guarantee unparalleled reliability and durability, allowing you to navigate the waters with confidence.

Driven by innovation and a commitment to excellence, Alamarin-Jet is your trusted partner for waterjet propulsion needs. Experience the difference with our world-class products, dedicated support team, and the trust of enthusiasts and industry professionals worldwide.

✓ **NEARLY 50 YEARS OF SUCCESSFUL EXPERIENCE IN DESIGNING, MANUFACTURING, AND SUPPLYING WATERJET PROPULSION SYSTEMS WORLDWIDE**

✓ **FINNISH QUALITY: OVER 90% MADE IN FINLAND, WITH THE REMAINING 10% SOURCED FROM THE EUROPEAN UNION**

✓ **A BROAD RANGE OF WATERJET SIZES SUITABLE FOR INPUT POWER OF UP TO 1,500 KW**

✓ **BEST POWER-TO-SIZE-TO-WEIGHT CHARACTERISTICS ON THE MARKET**

✓ **HIGHLY ACCURATE PERFORMANCE CALCULATIONS, ACHIEVED THROUGH THE LATEST SOFTWARE AND YEARS OF EXPERIENCE**

✓ **FASTEST PRODUCTION LEAD TIMES IN THE INDUSTRY**

✓ **COMPANY DEDICATED TO SERVICE AND SUPPORT**

✓ **DEALER AND SERVICE NETWORK SPANNING OVER 50 COUNTRIES**

✓ **DIRECT FACTORY SUPPORT AVAILABLE FOR ALL CUSTOMERS**

A reliable and skilled dealer network covers 50+ countries all around the world, providing rapid response and delivering service and spare parts when needed the most. Alamarin-Jet constantly works on developing the network in order to maintain the highest possible level of support.



Omega 42



STAINLESS STEEL PUMP UNIT

DAS:
0-deg &
4-deg shaft options

Integrated
Sigma
Control
System

FIBS:
Frame
Integrated
Bearing
Structure

MIG:
Modular
Intake
Geometry

Structural
bulkhead
adapter

SPECS



PUMP TYPE
MIXED FLOW,
SINGLE STAGE



IMPELLER SHAFT RPM
MAX. 2300 1/MIN



DRY WEIGHT
880 KG
(1940 LBS)

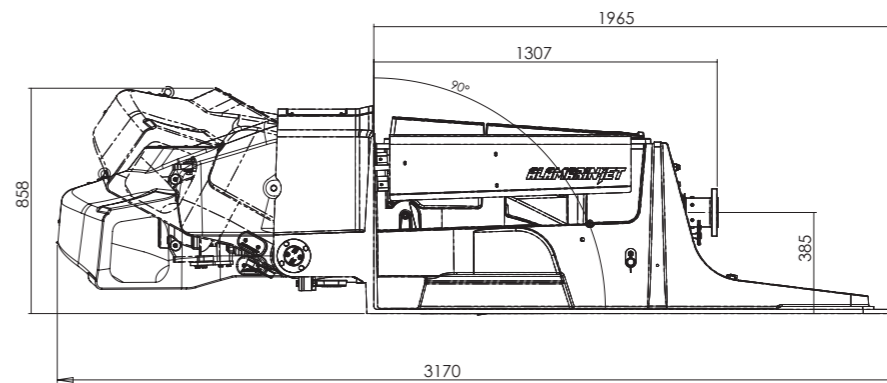

IMPELLER DIAMETER
MAX. 480MM
(18.9")



MAX INPUT POWER
1500 KW
(2040 HP)



MATERIALS
ALUMINIUM,
STAINLESS STEEL



REVERSE DEFLECTOR CONTROL
HYDRAULIC OR
SIGMA CONTROLS

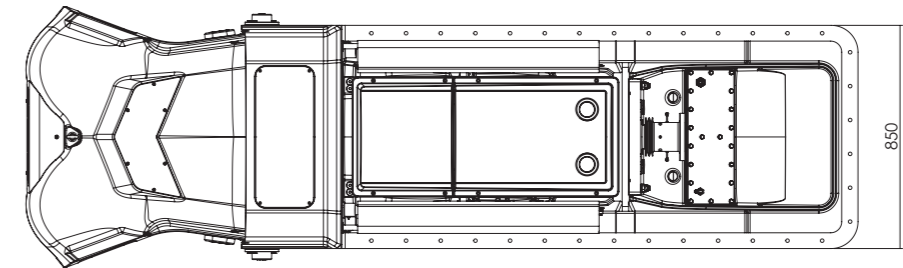

OMEGA 42 POWER/RPM COVERAGE

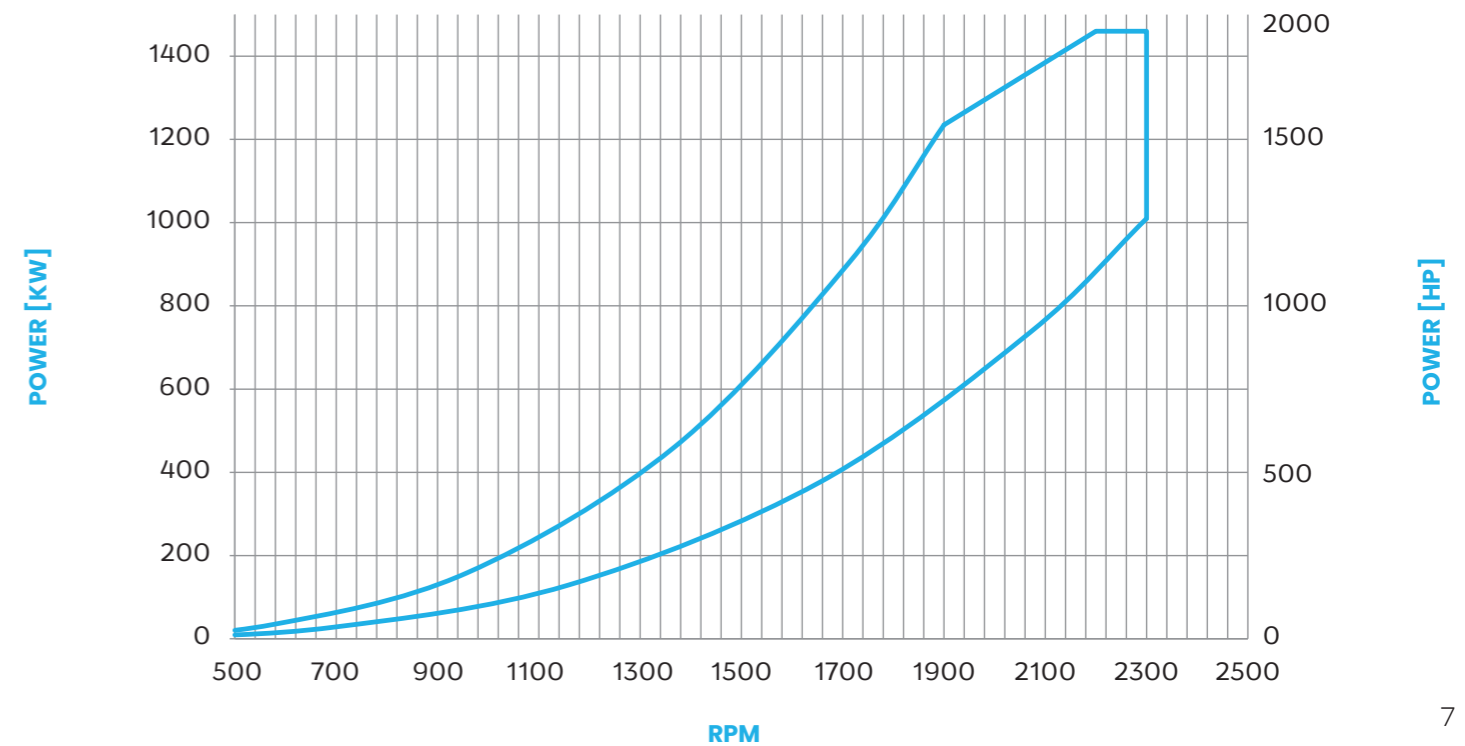

Omega 37



STAINLESS STEEL PUMP UNIT

DAS:
0-deg &
4-deg shaft
options

Integrated
Sigma
Control
System

FIBS:
Frame
Integrated
Bearing
Structure

MIG:
Modular
Intake
Geometry

Structural
bulkhead
adapter

SPECS



PUMP TYPE
MIXED FLOW,
SINGLE STAGE



IMPELLER SHAFT RPM
MAX. 2550 1/MIN



DRY WEIGHT
750-770 KG
(1653-1698 LBS)

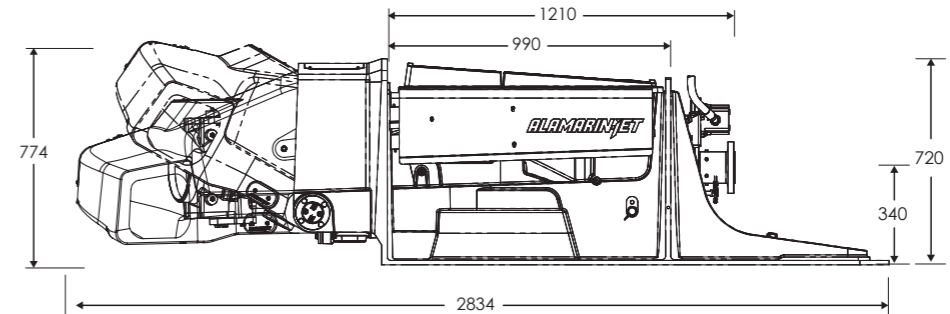

IMPELLER DIAMETER
MAX. 430 MM
(16.9")



MAX INPUT POWER
1000KW
(1360 HP)



MATERIALS
ALUMINIUM,
STAINLESS STEEL



REVERSE DEFLECTOR CONTROL
HYDRAULIC OR
SIGMA CONTROLS

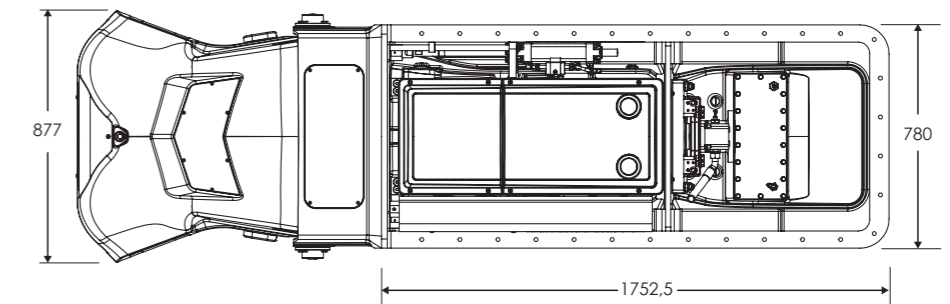

OMEGA 37 POWER/RPM COVERAGE

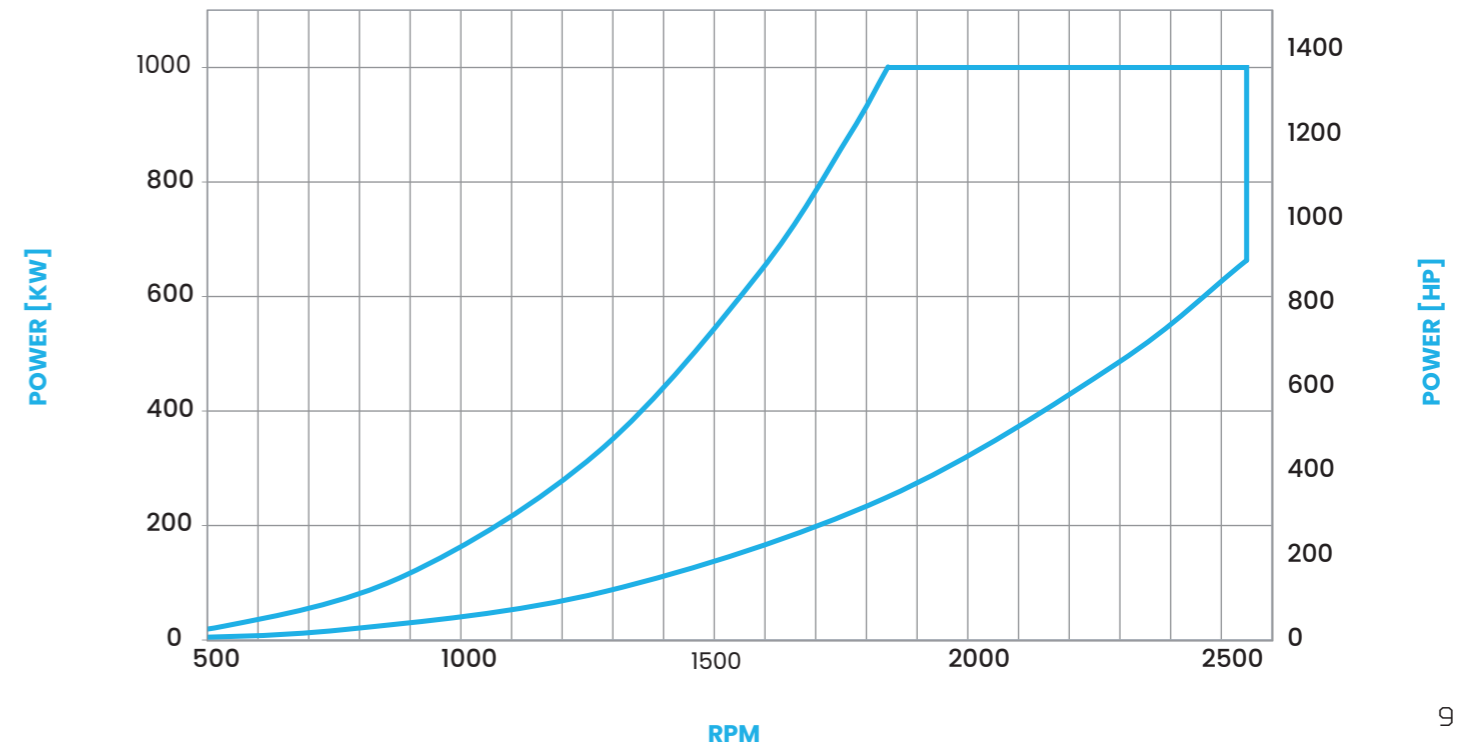

AJ 340

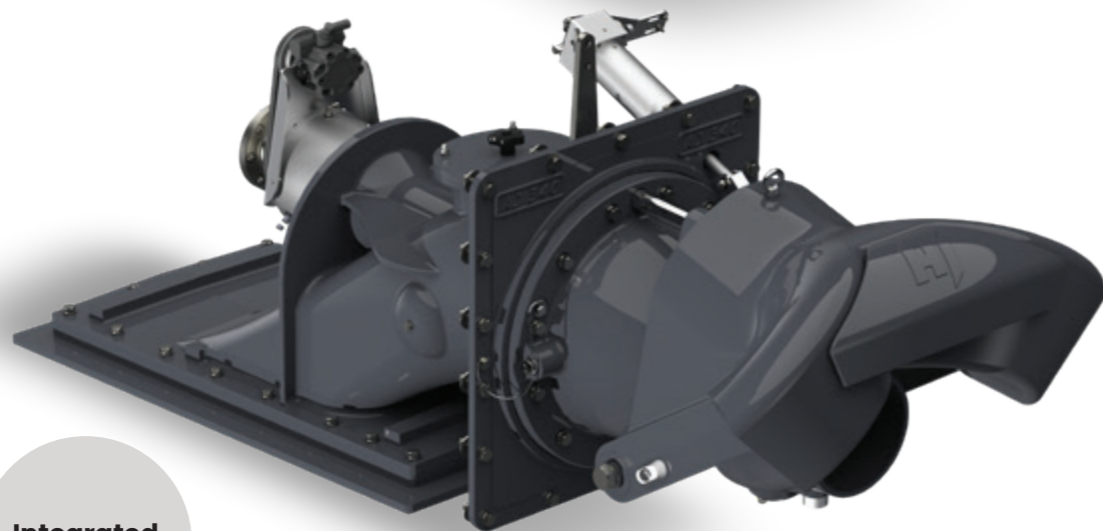
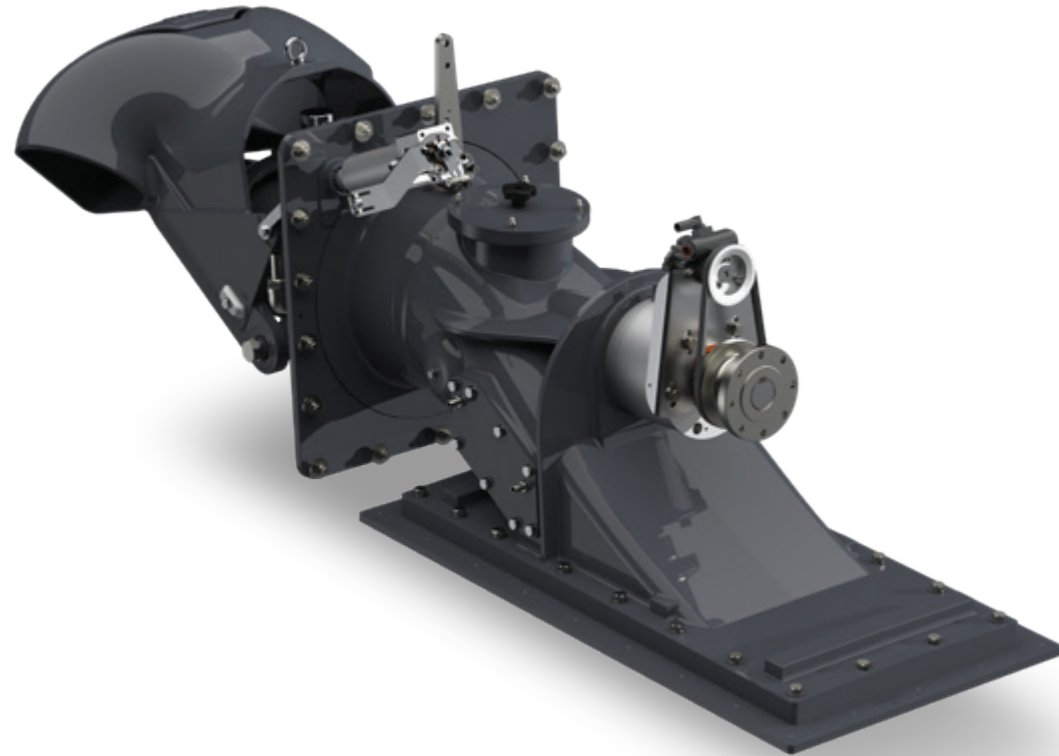

0-deg & 5-deg installation options

Integrated oil cooler

SPECS



PUMP TYPE
MIXED FLOW,
SINGLE STAGE



IMPELLER SHAFT RPM
MAX. 3300 1/MIN



DRY WEIGHT
272 KG
(600 LBS)

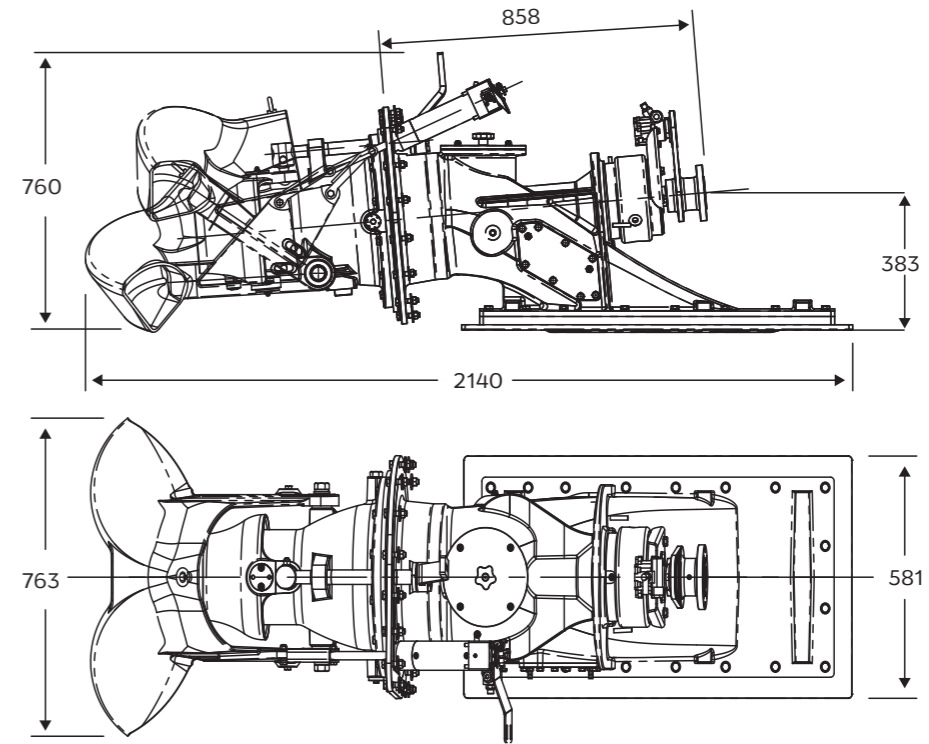

IMPELLER DIAMETER
MAX. 335 MM
(13.2")



MAX INPUT POWER
550 KW
(750 MHP)



MATERIALS
ALUMINIUM,
STAINLESS STEEL



REVERSE DEFLECTOR CONTROL
HYDRAULIC OR
SIGMA CONTROLS

AJ 340 POWER/RPM COVERAGE

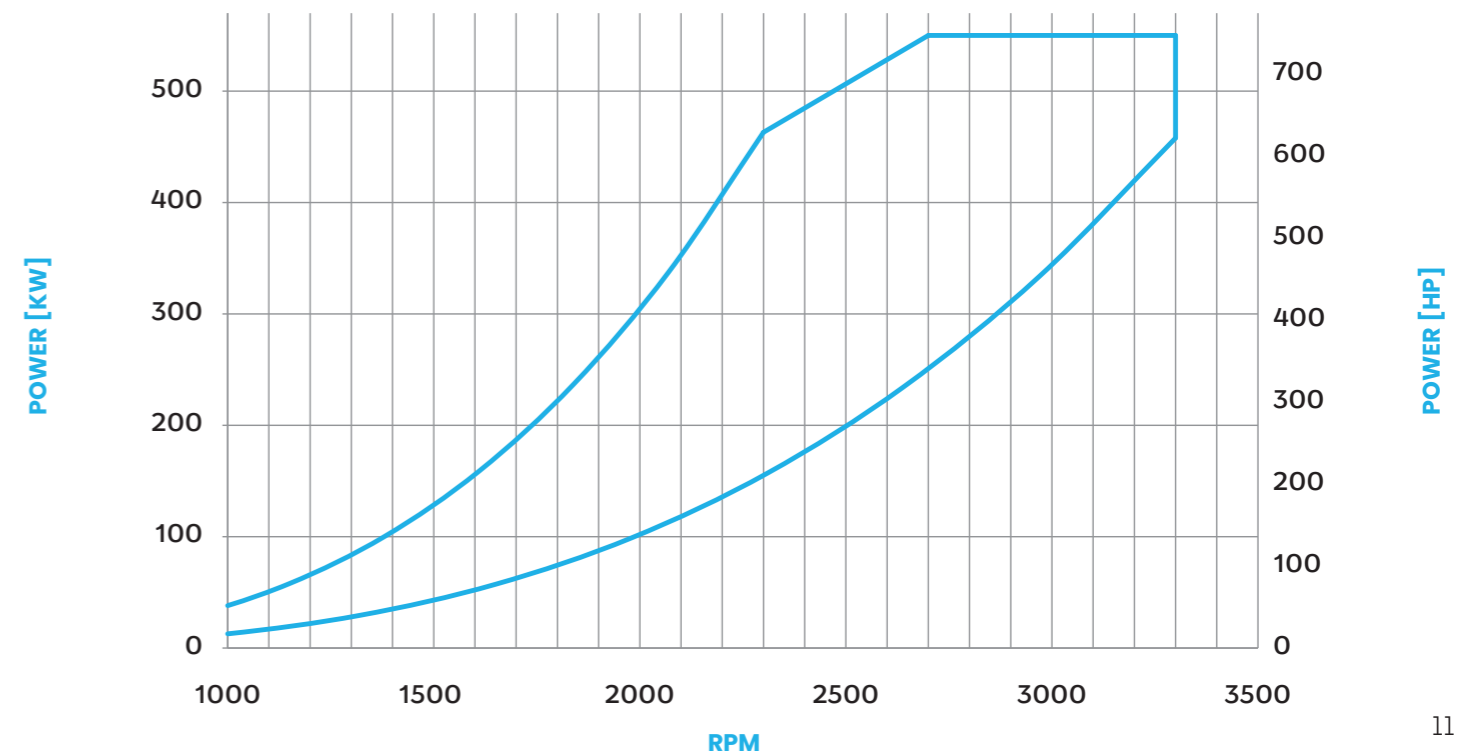

AJ 285

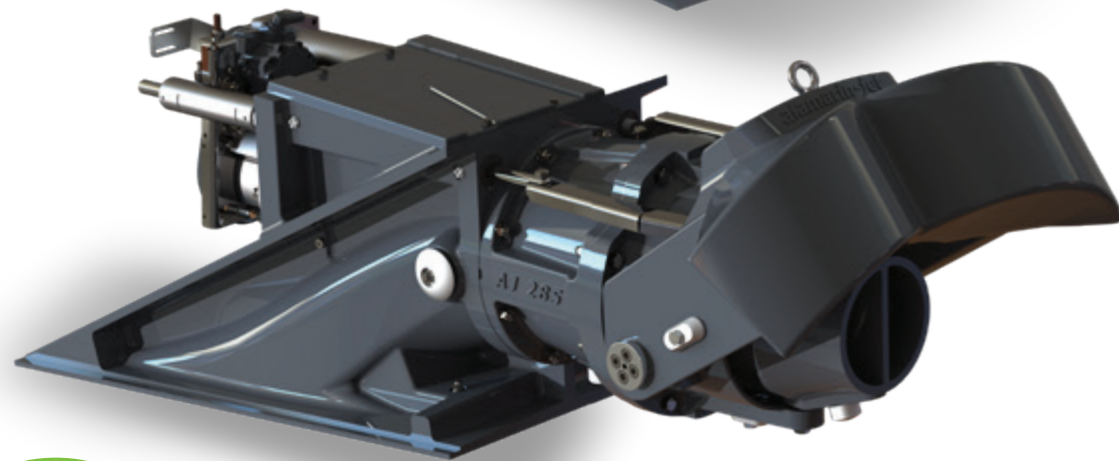
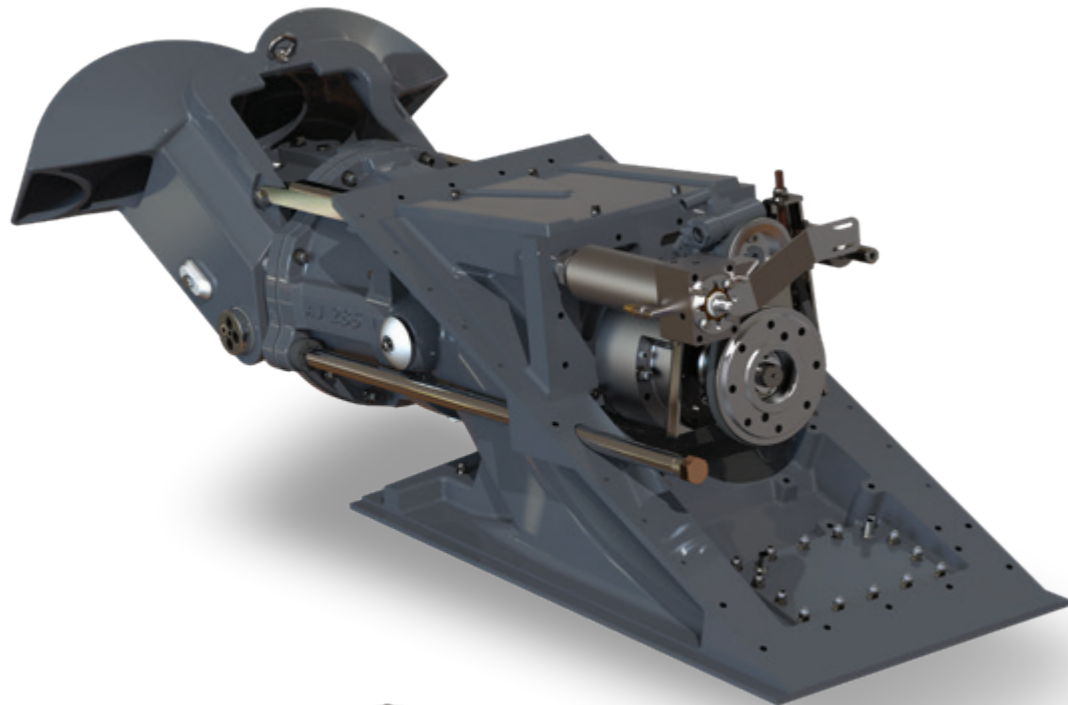

TWO INSTALLATION OPTIONS

Patented Combi-frame technology

Integrated oil cooler and steering cylinder

SPECS



PUMP TYPE
MIXED FLOW,
SINGLE STAGE



IMPELLER SHAFT RPM
MAX. 3700 1/MIN



DRY WEIGHT
181 KG
(399 LBS)

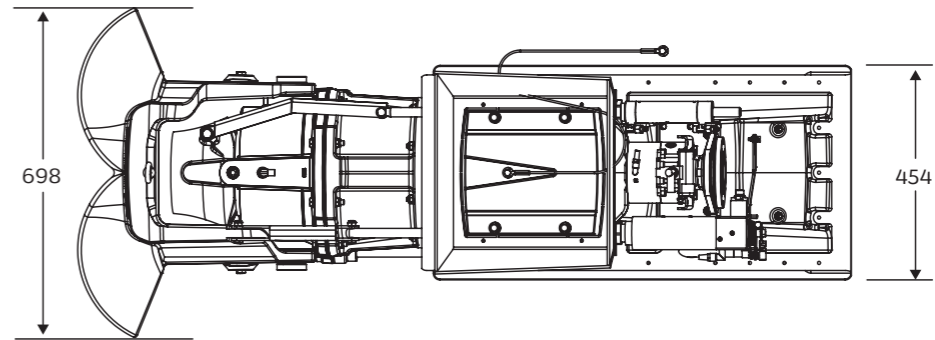
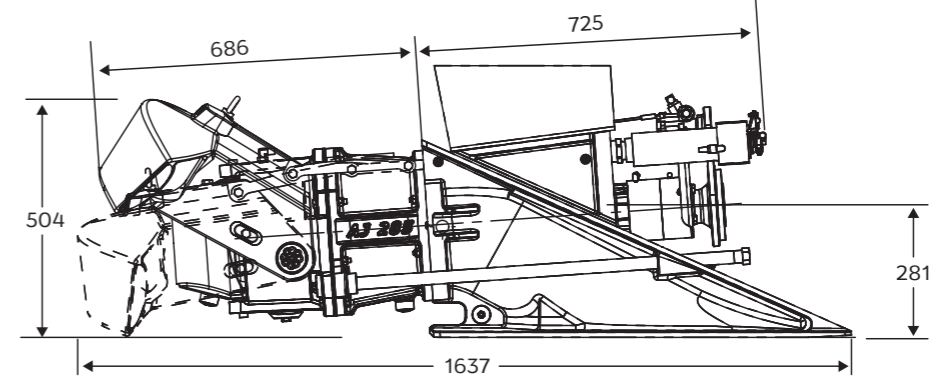

IMPELLER DIAMETER
MAX. 288 MM
(11.3")



MAX INPUT POWER
368 KW
(500 MHP)



MATERIALS
ALUMINIUM,
STAINLESS STEEL



REVERSE DEFLECTOR CONTROL
HYDRAULIC OR
SIGMA CONTROLS

AJ 285 POWER/RPM COVERAGE

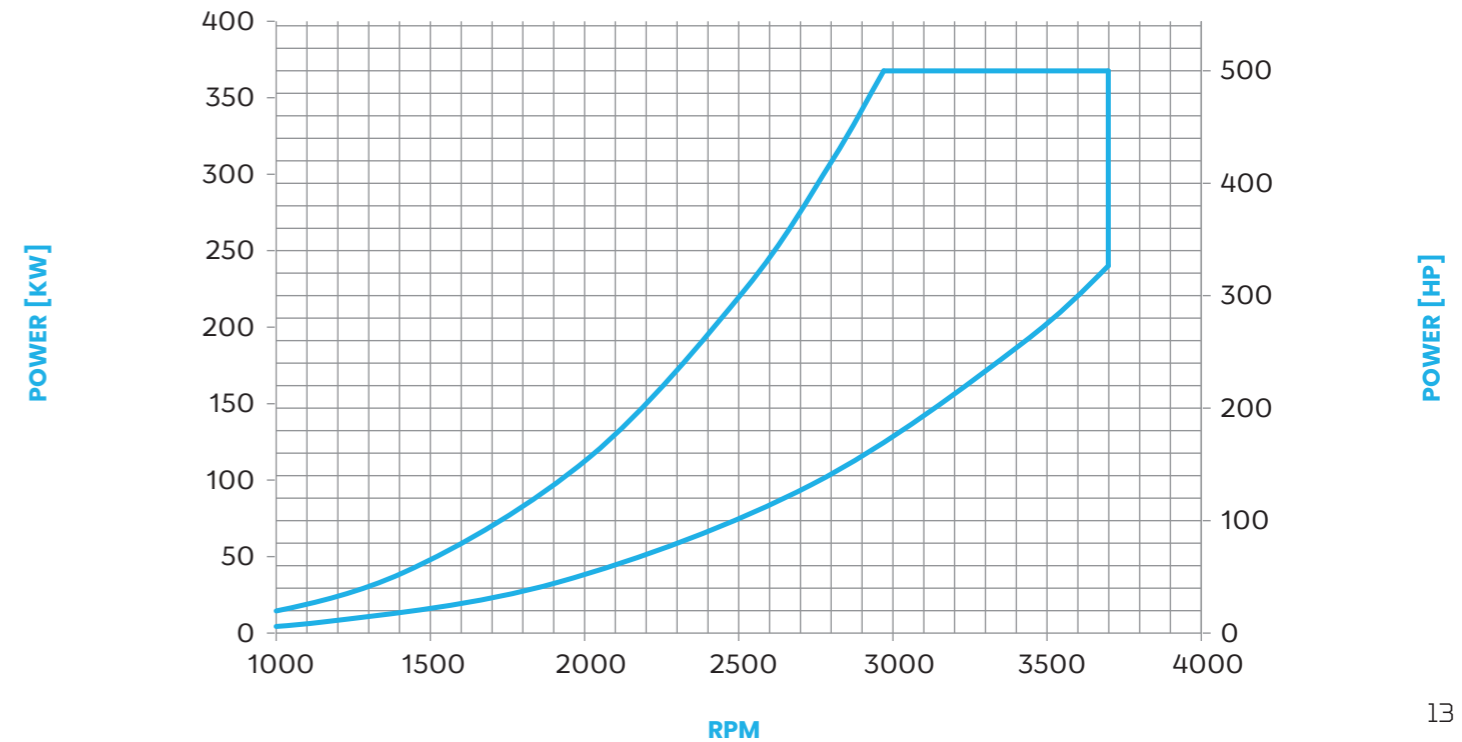

AJ 245

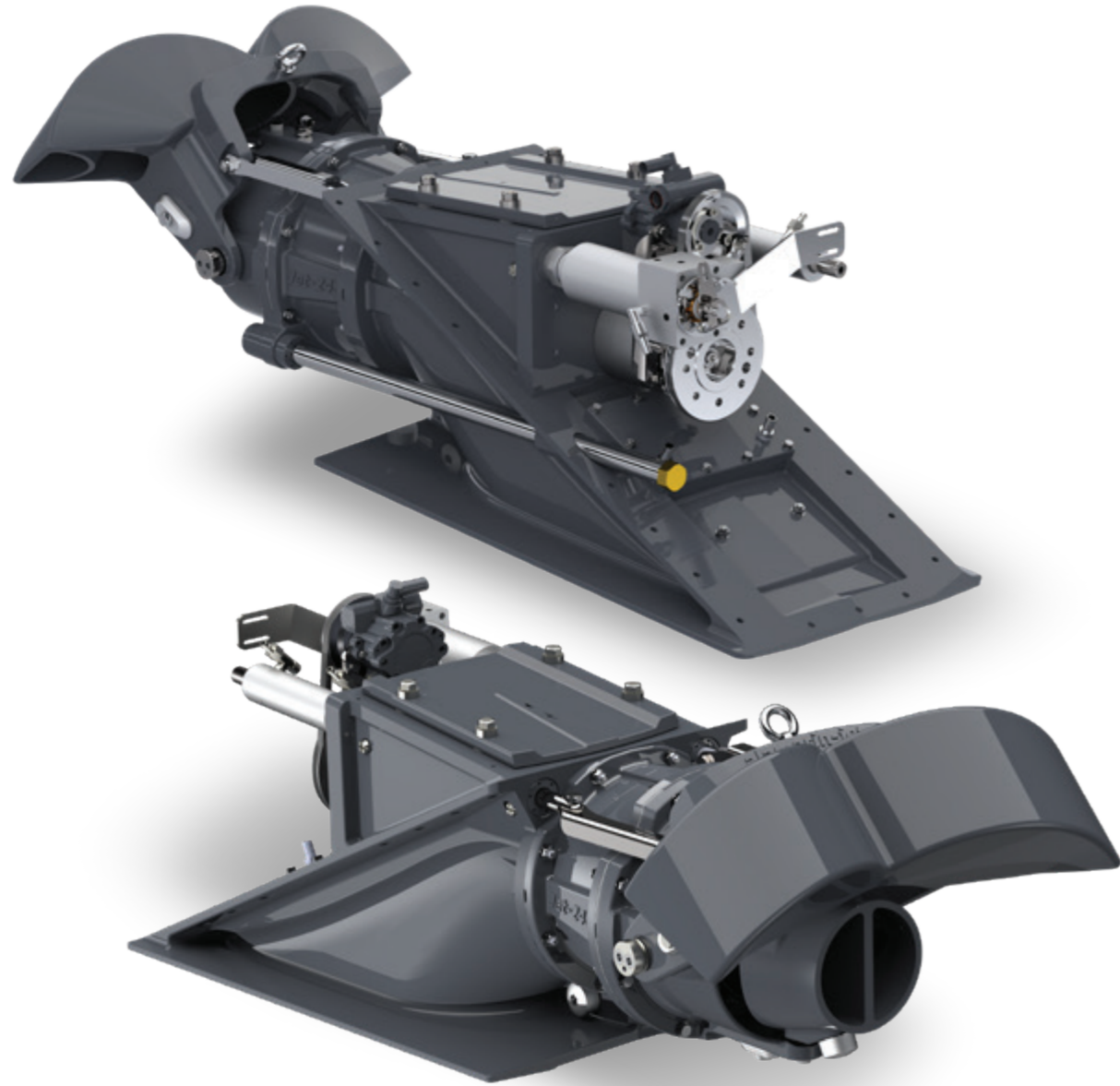

TWO INSTALLATION OPTIONS

Patented Combi-frame technology

Integrated oil cooler and steering cylinder

SPECS



PUMP TYPE
MIXED FLOW,
SINGLE STAGE



IMPELLER SHAFT RPM
MAX. 4600 1/MIN



DRY WEIGHT
105 KG
(231 LBS)

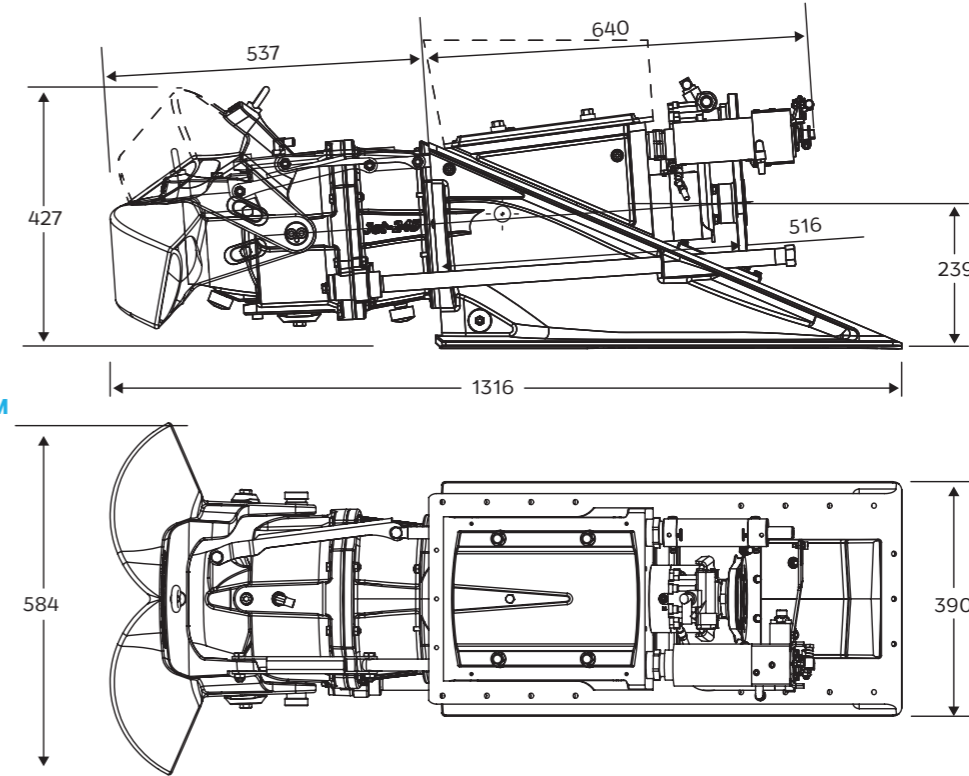

IMPELLER DIAMETER
MAX. 245 MM
(9.6")



MAX INPUT POWER
235 KW
(320 MHP)



MATERIALS
ALUMINIUM,
STAINLESS STEEL



REVERSE DEFLECTOR CONTROL
HYDRAULIC OR
SIGMA CONTROLS

AJ 245 POWER/RPM COVERAGE

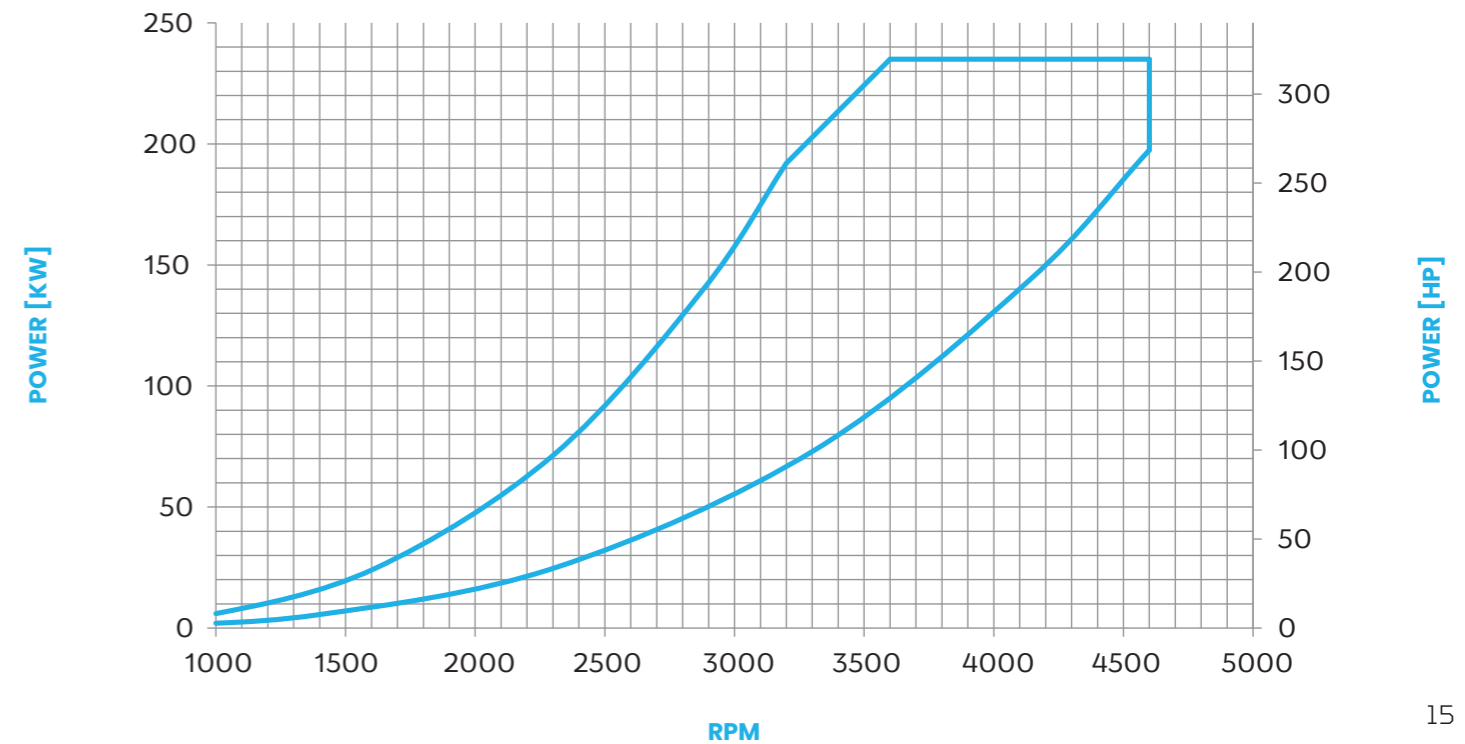

AJ 230

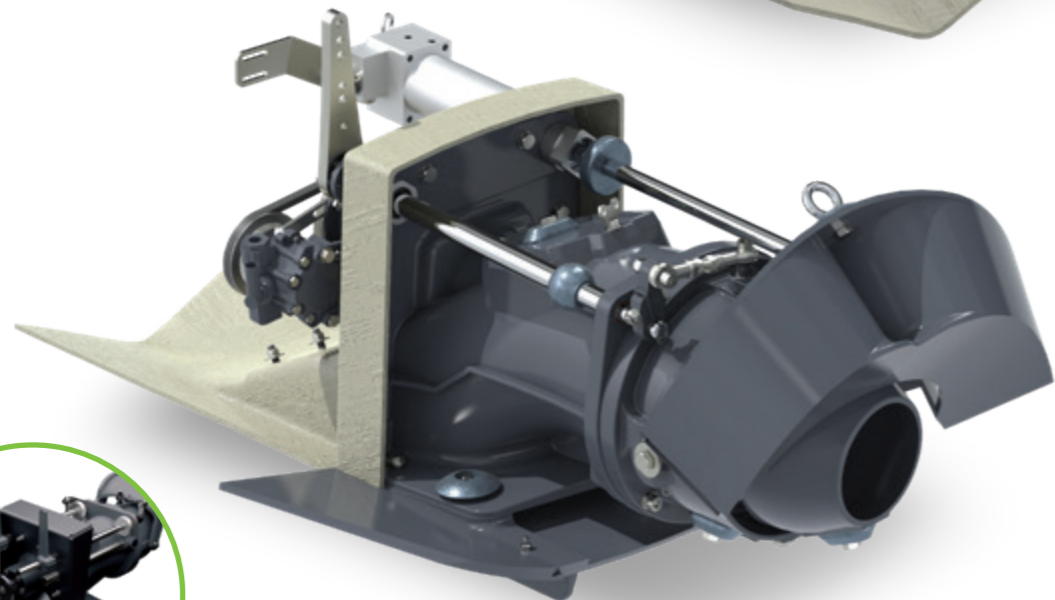
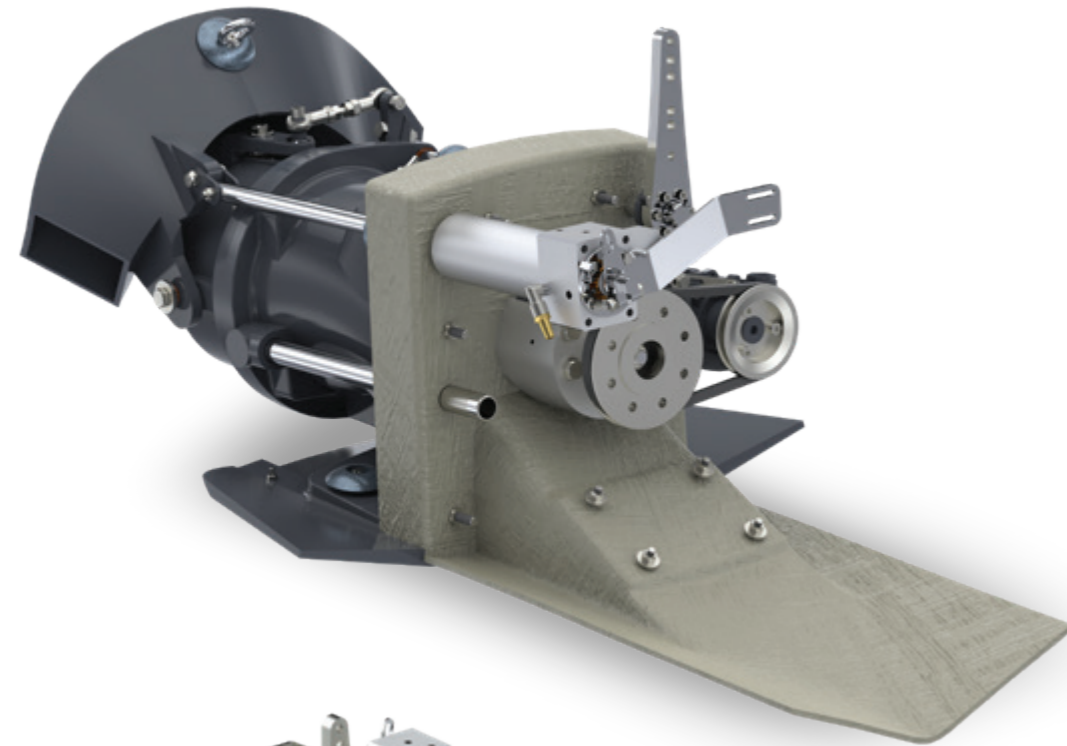



SPECS

 **PUMP TYPE**
MIXED FLOW

 **IMPELLER SHAFT RPM**
MAX. 4600 1/MIN

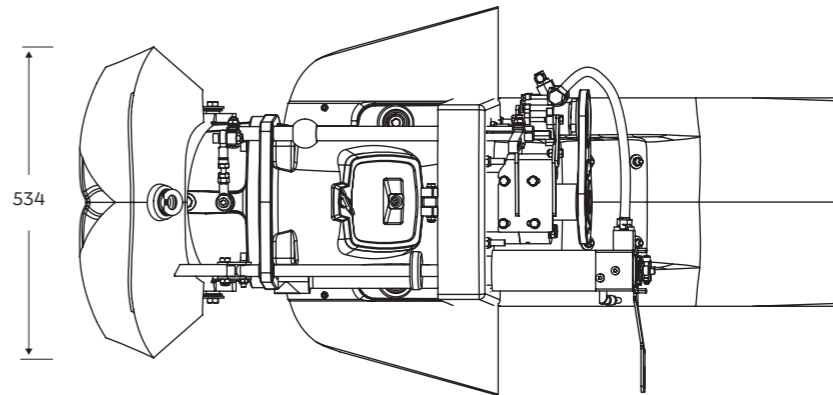
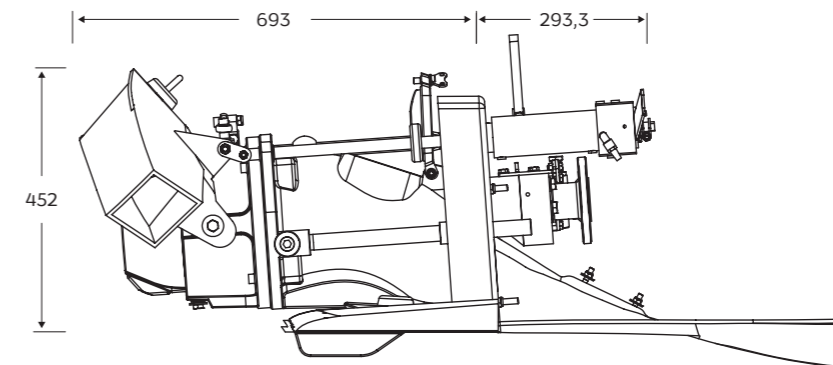
 **DRY WEIGHT**
81 KG
(179 LBS)



 **IMPELLER DIAMETER**
MAX. 228 MM / 9"

 **MAX INPUT POWER**
190 KW / 260 HP

 **MATERIALS**
ALUMINIUM,
STAINLESS STEEL

 **REVERSE DEFLECTOR CONTROL**
HYDRAULIC

AJ 230 POWER/RPM COVERAGE

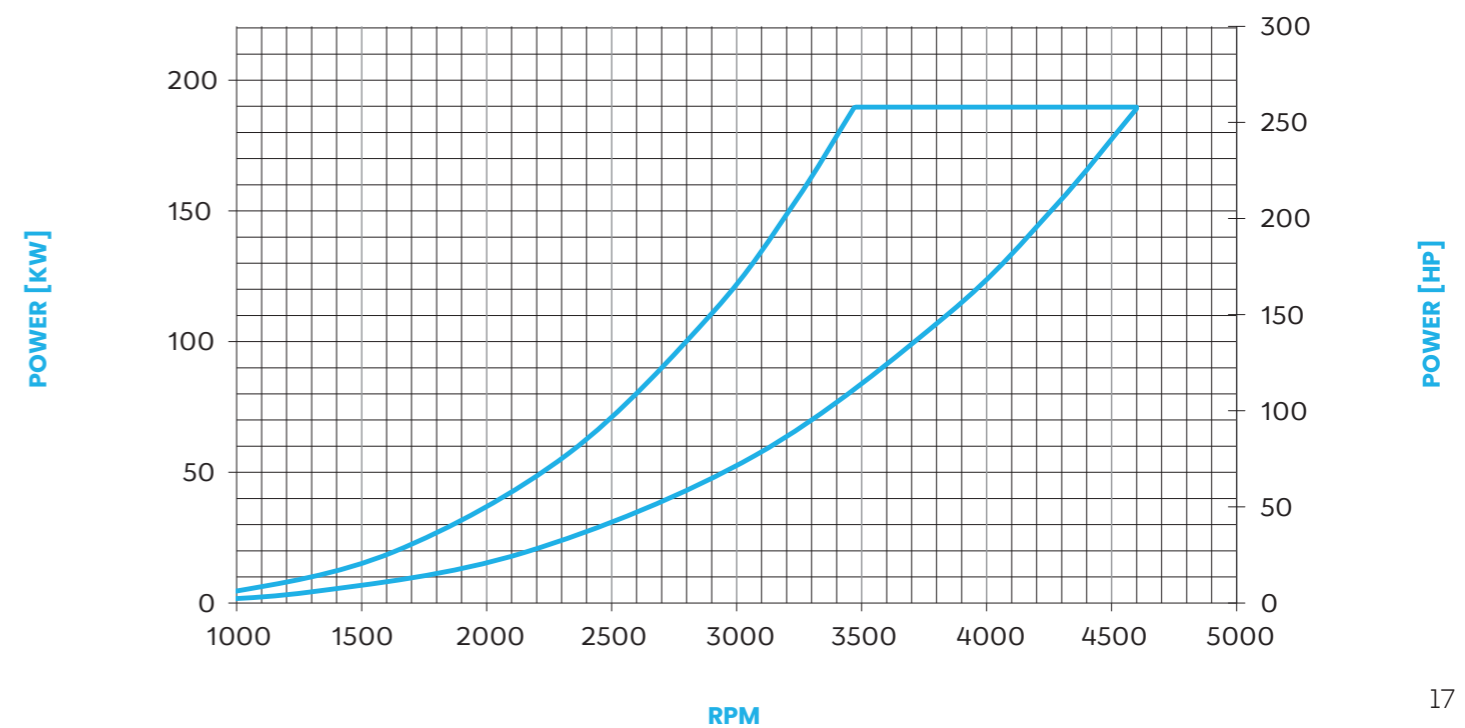

AJ 180/185

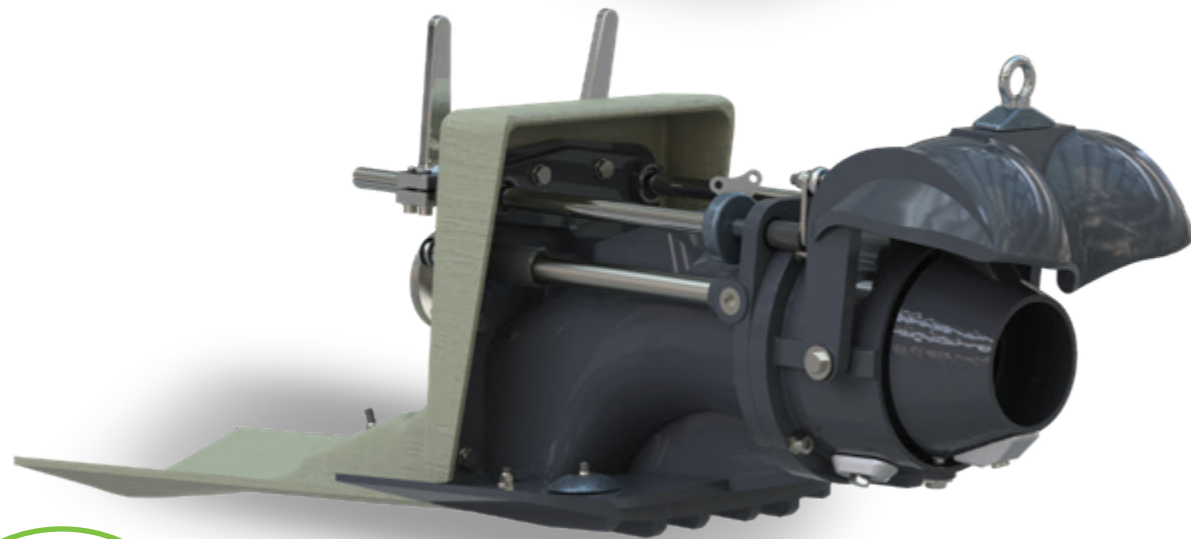
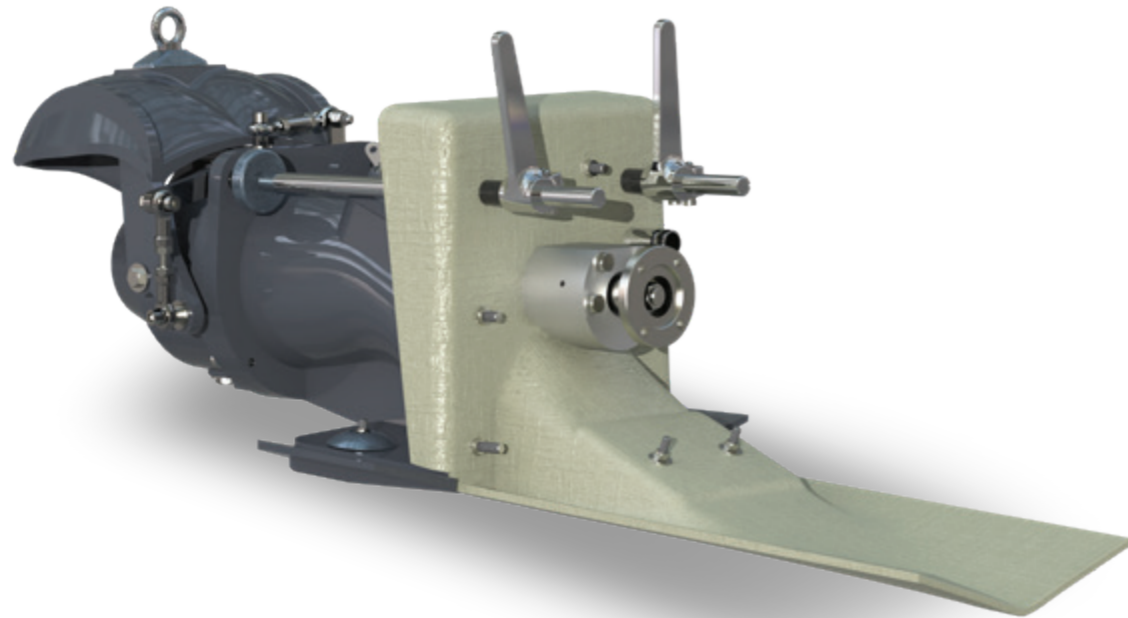

SPECS



PUMP TYPE
MIXED FLOW,
SINGLE STAGE



IMPELLER SHAFT RPM
MAX. 5000 1/MIN



DRY WEIGHT
48 / 50 KG
(106 / 110 LBS)

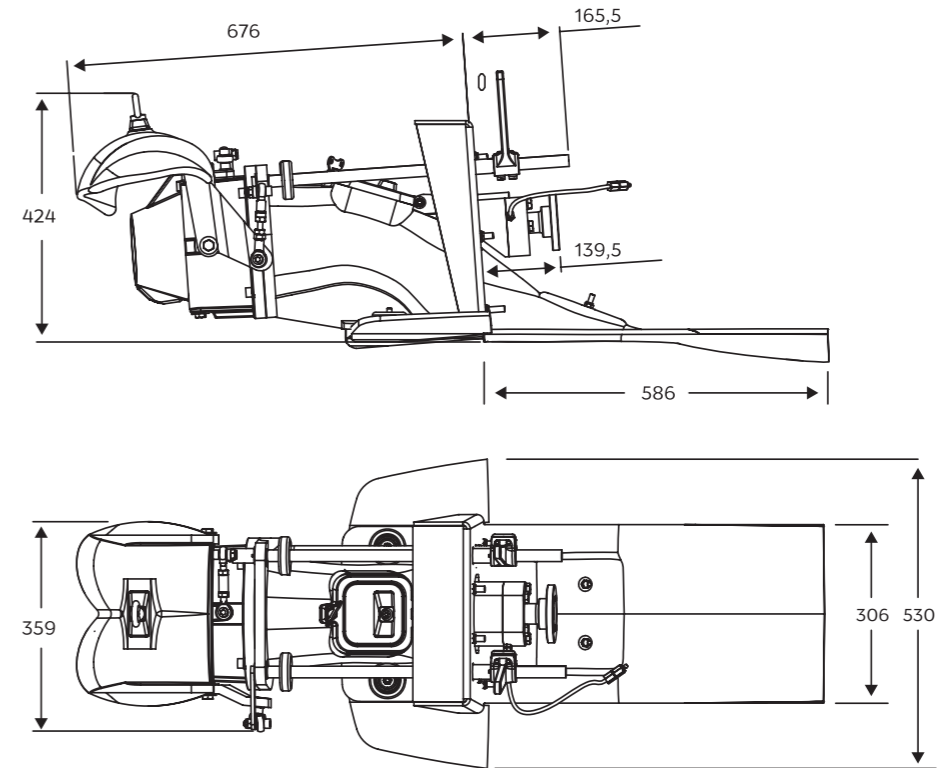

IMPELLER DIAMETER
MAX. 192 / 197 MM
(7.6" / 7.8")



MAX INPUT POWER
120 KW
(163 MHP)



MATERIALS
ALUMINIUM,
STAINLESS STEEL



REVERSE DEFLECTOR CONTROL
MECHANICAL OR
ELECTRICAL (ACU)

AJ 180/185 POWER/RPM COVERAGE

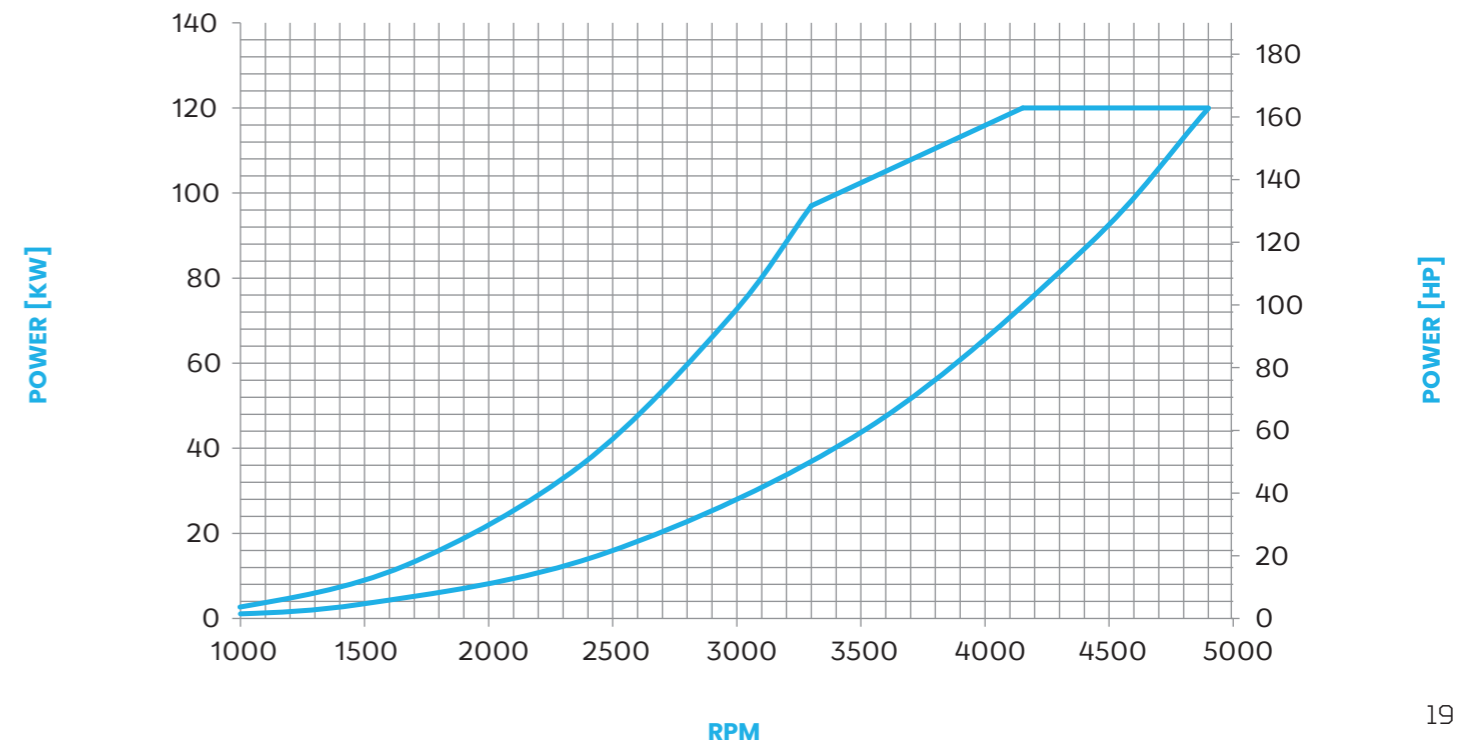

AJ 160



REVERSING DEFLECTOR CONTROL

SPECS



PUMP TYPE
MIXED FLOW,
SINGLE STAGE



IMPELLER SHAFT RPM
MAX. 5000 1/MIN



DRY WEIGHT
38 KG
(84 LBS)

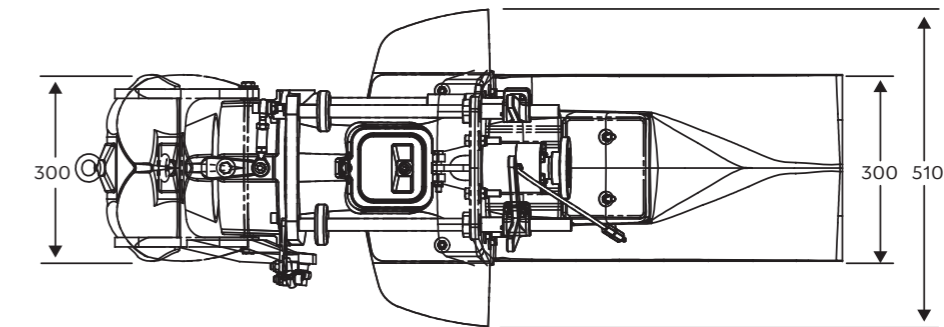
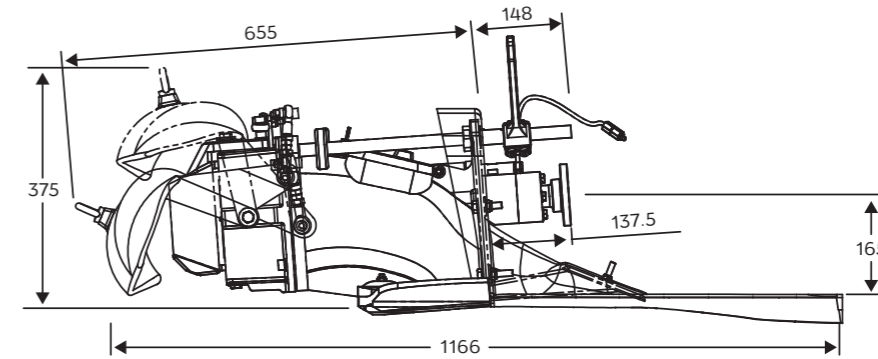

IMPELLER DIAMETER
MAX. 186 MM
(7.3")



MAX INPUT POWER
100 KW
(136 MHP)



MATERIALS
ALUMINIUM,
STAINLESS STEEL



REVERSE DEFLECTOR CONTROL
MECHANICAL OR
ELECTRICAL (ACU)

AJ 160 POWER/RPM COVERAGE

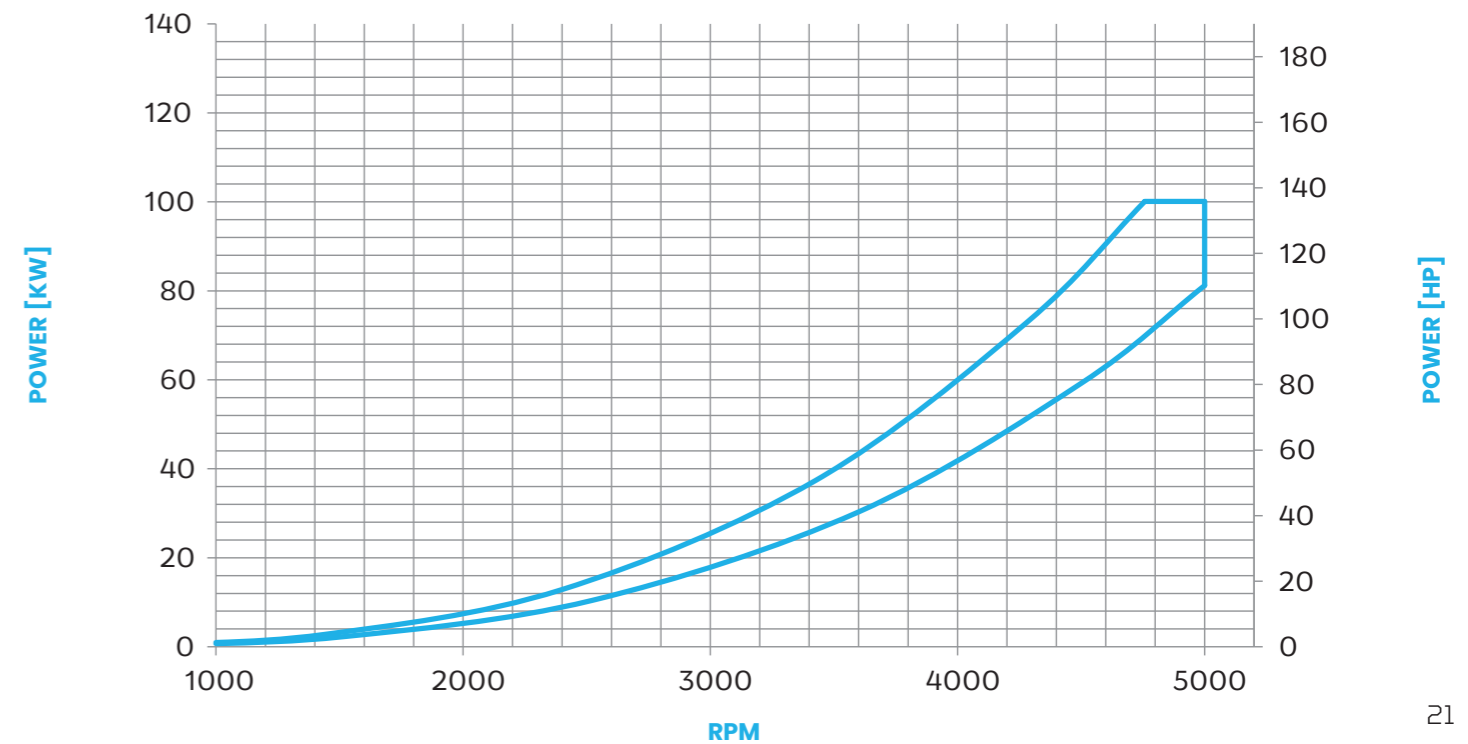

SIGMA

ELECTRO-HYDRAULIC INTEGRATED DRIVE-BY-WIRE CONTROL SYSTEM

Sigma Control System is an electro-hydraulic integrated drive-by-wire control system that supports installations ranging from single to quadruple waterjets. Built on a modular architecture, the system's features can be customized by integrating modules tailored to user requirements.

In addition to the standard Sigma Control System configuration, Intelligent Dynamics is available as an add-on feature. Developed with future markets and industries in mind, Intelligent Dynamics ensures effortless integration with third-party autonomous and unmanned systems.

This advanced feature also includes highly sophisticated position and heading-keeping functions, providing significant operational benefits across a wide range of vessel types and applications.

TECHNICAL:

The Sigma Control System is built on a CAN network, with its core components—the Jet Controller Units (JCU) and Helm Control Units (HCU)—connected via a standardized cable system. Each waterjet is equipped with its own independent JCU and dedicated control hydraulics, ensuring enhanced redundancy. Each JCU works also as an individual control network node (CAN Bus). The primary BUS system is designed to carry both, electric power for each JCU node and network communications.

In installations with twin or multiple waterjets, two electrically separated primary BUS lines are implemented to enhance redundancy. All primary control heads are capable to deliver isolated dual output. Each Control Head axis of movement features two electronically separated circuits, ensuring that each propulsion line is completely independent and isolated. This design guarantees that a single point of failure will not affect other primary BUS propulsion lines, delivering unmatched reliability.



INTELLIGENT DYNAMIC FEATURES



JOYSTICK

Ideal for docking and low-speed maneuvering in harbor environments, Joystick mode enables the vessel to move precisely in the direction and rotation set by the joystick.



AUTOPILOT

Autopilot provides intuitive control with three advanced modes: Heading Hold, Course Mode, and Track Mode.



VIRTUAL ANCHOR

Activating Virtual Anchor mode sets a virtual anchor point, allowing the system to maintain the vessel's position within a defined radius while automatically orienting the bow toward the wind for stability.



DYNAMIC POSITIONING (DP)

Dynamic Positioning automatically maintains the vessel's position and heading, counteracting external forces such as wind and waves.



SUPPORT FOR EXTERNAL AUTOPILOT

In addition to its built-in Sigma Autopilot, the system features an interface that ensures compatibility with external autopilot systems.



EXIF – EXTERNAL INTERFACE

USV Ready – Offers a comprehensive CAN bus JET-Control interface with engine management, enabling rapid deployment for Unmanned Surface Vehicles (USVs).

You can find more information about Intelligent Dynamic Features through the link:



SPECIFICATIONS

- ✓ The powerful 7-inch display features 10 soft keys and a multi-touch screen
- ✓ Modular and scalable architecture – From single installation up to 4 waterjets
- ✓ Multiple control stations
- ✓ Multiple control head arrangement options
- ✓ Flexible BUS architecture – Each waterjet unit functions as an independent BUS node
- ✓ Factory-made modular cabling system – no custom cables required
- ✓ Increased Redundancy – Based on individual drive lines and multiple control law levels
- ✓ Easy to approach design
- ✓ Installation is based on plug-n-play modules
- ✓ Intuitive step-by-step commissioning procedure
- ✓ Easy-to-use, high-resolution display with a modern UI/UX usability
- ✓ Digital Engine Interface – Direct digital CAN-CAN throttle control for responsive and delay-free throttle management
- ✓ Sophisticated Diagnostics – Offers multiple data logging and diagnostic options
- ✓ Intelligent self-monitoring system. Temperature, Pressure and Fluid Levels are continuously monitored

ACU

The Actuator Control Unit (ACU) system is a modular propulsion control system designed for adaptability across multiple configurations through the simple selection of modular components.

The ACU system can control the waterjet deflector, waterjet steering, engine throttle, and gearbox engagement.

The main unit of the system is the ACU itself, a controller box capable of controlling one (1) actuator at a time within the overall system.

The ACU can accept its own internal potentiometer control, an external signal supply (typically 0-5v), or a CAN signal (NMEA 2000, rudder message).

The ACU can be configured via the integrated button and 'traffic light' LED's, or a Service Tool item (option).

ACU SERVICE TOOL (MOBILE APP)

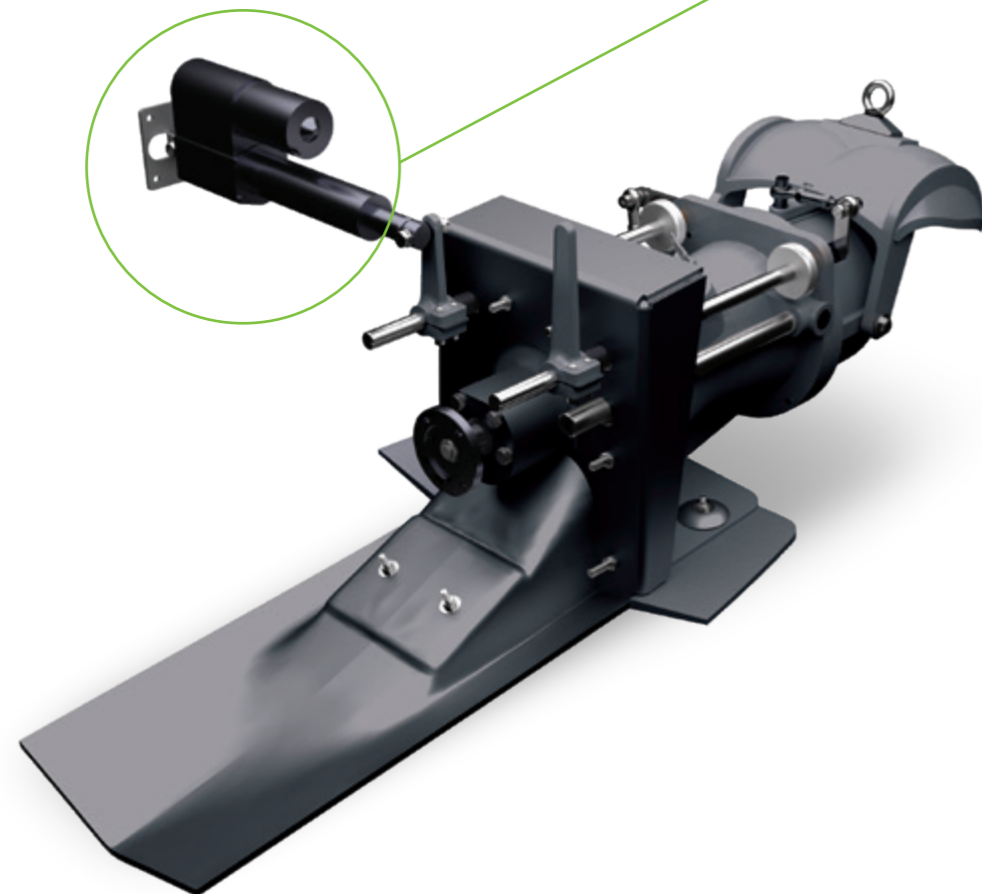
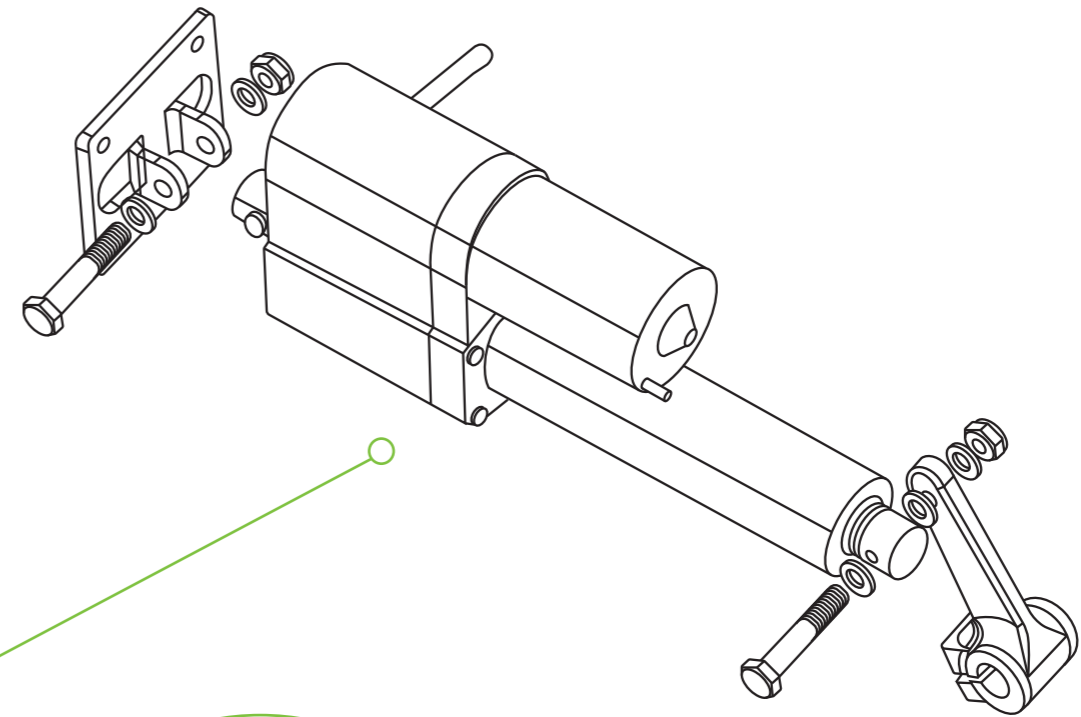

- X1
- OVDC
 - +12VDC
 - Actuator neg
 - Actuator pos

- X2
- Pot. 1 GND
 - Pot. 1 signal
 - Pot. 1 +5VDC
 - CAN-L
 - CAN-H
 - Alarm
 - Actuator pot GND
 - Actuator pot signal
 - Actuator pot +5V
 - Pot. 2 GND
 - Pot. 2 signal
 - Pot. 2 +5VDC

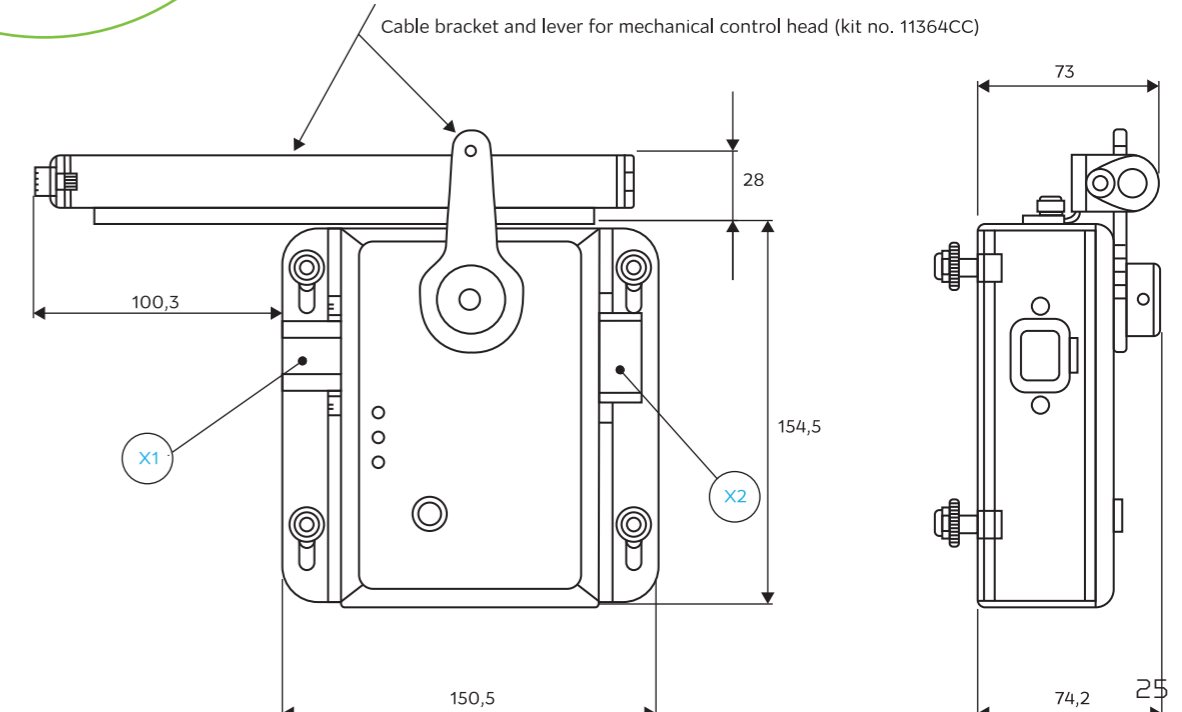

Delta DP

PRECISE DP CONTROL

FOR THRUSTERS AND RUDDERS

Delta DP is a modular high-level propulsion control system that integrates a vessel's propulsion, steering, and navigation systems. It provides three main controlling modes: Manual Control, Dynamic Positioning Mode and Autopilot Mode. The DP capabilities include dynamic positioning, virtual anchor, and 3-axis joystick propulsion force control. Additionally, Delta DP features automatic heading keeping, track keeping, and an external waypoint autopilot interface compatible with NMEA2000 or NMEA0183 autopilot computers.

SYSTEM ARCHITECTURE

- ✓ Modular CAN bus connected system
- ✓ Proprietary J1939-Inspired CAN network
- ✓ NMEA2000 interface for GPS and external autopilot
- ✓ 7-inch display
- ✓ Robust real-time control module for each thruster

CONTROL HEAD OPTIONS

- ✓ Twin-levers option
- ✓ 3-axis joystick
- ✓ E-Helm

RUDDER CONTROL OPTIONS

- ✓ "Bang bang" control
- ✓ PWM control for proportional valves

BOW THRUSTER CONTROL OPTIONS

- ✓ Analog signal
- ✓ PWM controlled proportional valves

INTELLIGENT FEATURES

- ✓ 3-axis joystick force control
- ✓ Dynamic positioning
- ✓ Virtual anchor
- ✓ Heading autopilot
- ✓ COG autopilot
- ✓ Track following autopilot

DRIVELINE CONTROL OPTIONS

- ✓ Optoisolated analog engine control
- ✓ J1939 CAN engine control
- ✓ Gearbox solenoid control
- ✓ ZF ClearCommand DP-interface option

Propulsion types:

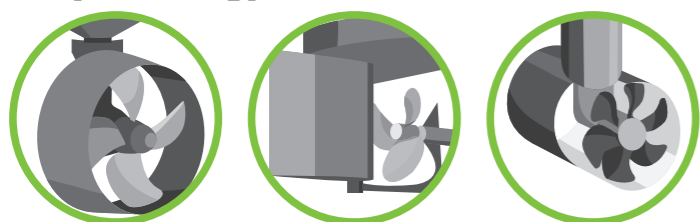

Vessel types:



Delta DP - System Diagram

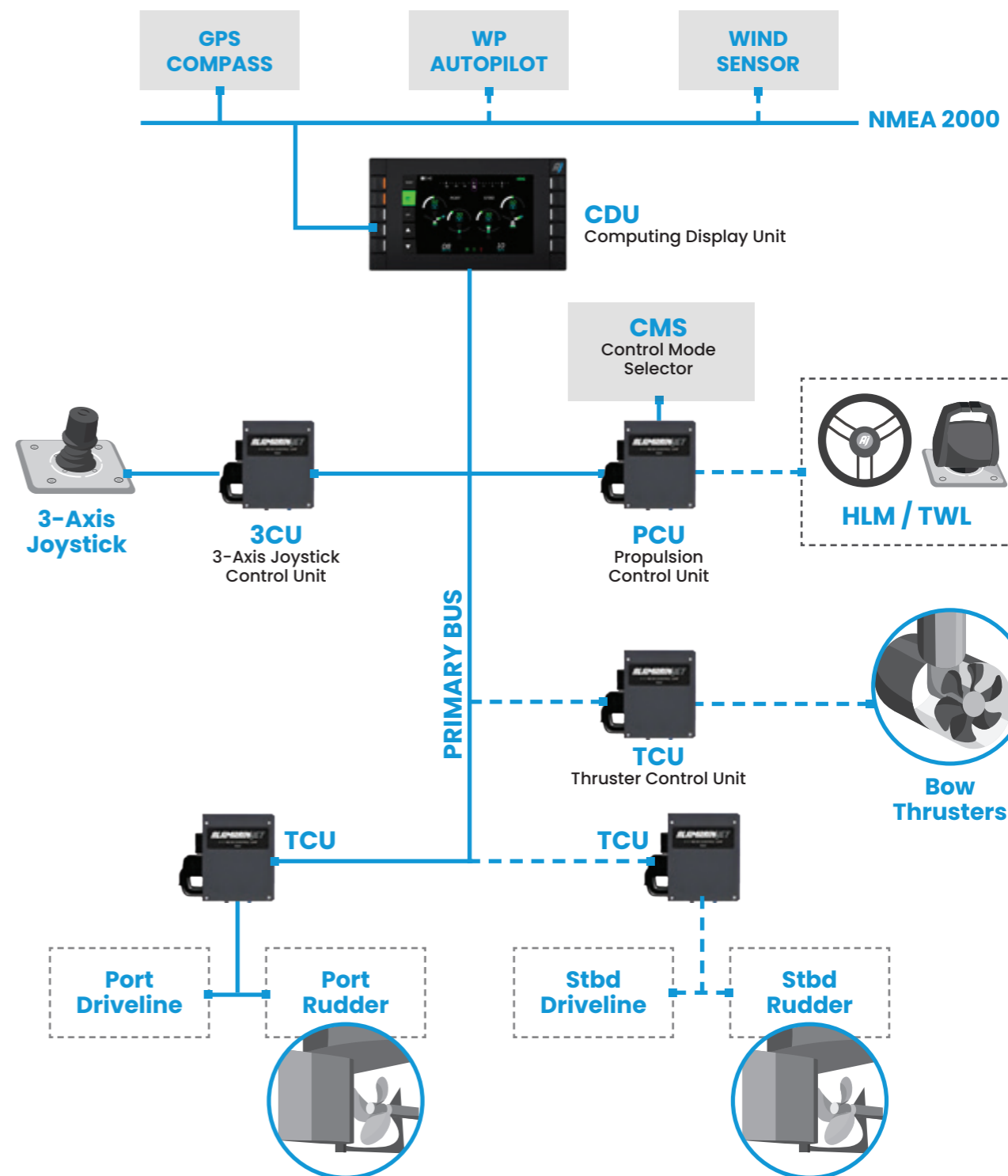



Alamarin-Jet Oy

Tuomisentie 16, FI-62300 Härmä, Finland

www.alamarinjet.com